

MILITARY SPECIFICATION

# CV7193-7276

SEMICONDUCTOR DEVICE

Description:- This specification covers the detail requirements for Silicon Voltage - regulator Diodes, and is in accordance with K1007, except as otherwise specified.

Mechanical Dimensions and Outlines:- K1007, Section B, 10.3.3.2 (10-32 UNF 2A thread).

Connections:- CV7193-7274, Stud Anode  
CV7235-7276, Stud Cathode

Absolute Maximum Ratings:-

Rating	P <sub>tot</sub>	T <sub>stud</sub>	T <sub>opp</sub>	T <sub>stg</sub>	Shook	Vibration	
Unit	W	°C	°C	°C	g	g	
Min.	-	-	-55	-55	-	-	
Max.	10	150	150	150	1500	20	
Note	1				2		

- NOTES:-
1. See derating curve Fig. 1 page 11.
  2. Duration 0.5 mS.

# CV7193 - 7276

## Primary Electrical Characteristics

		3	4	5	6	7	8	
		V(BR) nominal	V(BR) min.	V(BR) max.	I <sub>R</sub> test	Z(BR) max.	Z(BR) max.	
Stud Anode	Stud Cathode	V	V	V	mA	Ω	Ω	
CV7193	CV7235	3.9	3.7	4.1	500	12	-	
CV7194	CV7236	4.3	4.0	4.5	500	12	-	
CV7195	CV7237	4.7	4.4	5.0	500	12	-	
CV7196	CV7238	5.1	4.8	5.4	500	8	-	
CV7197	CV7239	5.6	5.3	6.0	500	8	-	
CV7198	CV7240	6.2	5.8	6.6	500	4	800	
CV7199	CV7241	6.8	6.4	7.2	200	4	500	
CV7200	CV7242	7.5	7.1	7.9	200	2.5	250	
CV7201	CV7243	8.2	7.7	8.7	200	2.5	250	
CV7202	CV7244	9.1	8.6	9.6	200	2.5	250	
CV7203	CV7245	10.0	9.4	10.6	200	2.5	250	
CV7204	CV7246	11.0	10.4	11.6	200	2.5	250	
CV7205	CV7247	12.0	11.4	12.6	200	2.5	250	
CV7206	CV7248	13.0	12.4	14.1	200	2.5	250	
CV7207	CV7249	15.0	13.9	15.6	100	5.0	250	
CV7208	CV7250	16.0	15.4	17.1	100	5	250	
CV7209	CV7251	18.0	16.9	19.1	100	5	250	
CV7210	CV7252	20.0	18.9	21.2	100	5	250	
CV7211	CV7253	22.0	20.8	23.3	100	5	250	
CV7212	CV7254	24.0	22.7	25.9	100	5	250	
CV7213	CV7255	27.0	25.1	28.9	100	5	250	
CV7214	CV7256	30.0	28.0	32.0	100	8	300	
CV7215	CV7257	33.0	31.0	35.0	50	8	300	
CV7216	CV7258	36.0	34.0	38.0	50	8	300	
CV7217	CV7259	39.0	37.0	41.0	50	8	300	
CV7218	CV7260	43.0	40.0	45.0	50	10	400	
CV7219	CV7261	47.0	44.0	50.0	50	10	400	
CV7220	CV7262	51.0	48.0	54.0	50	10	500	
CV7221	CV7263	56.0	53.0	60.0	50	10	500	
CV7222	CV7264	62.0	58.0	66.0	50	15	600	
CV7223	CV7265	68.0	64.0	72.0	20	50	600	
CV7224	CV7266	75.0	71.0	79.0	20	50	600	
CV7225	CV7267	82.0	77.0	87.0	20	50	700	
CV7226	CV7268	91.0	86.0	96.0	20	60	800	
CV7227	CV7269	100.0	94.0	106.0	20	60	900	
CV7228	CV7270	110.0	104.0	116.0	20	60	1100	
CV7229	CV7271	120.0	114.0	126.0	20	80	1200	
CV7230	CV7272	130.0	124.0	141.0	20	80	1300	
CV7231	CV7273	150.0	139.0	156.0	10	180	1500	
CV7232	CV7274	160.0	154.0	171.0	10	200	1600	
CV7233	CV7275	180.0	169.0	191.0	10	250	1850	
CV7234	CV7276	200.0	189.0	212.0	10	300	2000	
Conditions	I <sub>R</sub>	mA	See Col. 6 Page 2				See Col. 6 page 2	1.0
	T <sub>stud</sub>	°C	100				25	25

1	2	3	4	5	6	
		$S_z$ min.	$S_z$ min.	$S_z$ max.	$Z(B.R.)$ max.	
Stud Anode	Stud Cathode	%/°C	%/°C	%/°C	$\Omega$	
CV7193	CV7235	-0.10	-0.06	-0.02	-	
CV7194	CV7235	-0.08	-0.04	0.00	-	
CV7195	CV7237	-0.06	-0.02	0.02	-	
CV7196	CV7238	-0.045	-0.005	0.035	-	
CV7197	CV7239	-0.03	0.01	0.05	-	
CV7198	CV7240	-0.01	0.03	0.07	1200	
CV7199	CV7241	-0.01	0.03	0.07	750	
CV7200	CV7242	0.00	0.04	0.08	375	
CV7201	CV7243	0.00	0.04	0.08	375	
CV7202	CV7244	0.01	0.05	0.09	375	
CV7203	CV7245	0.01	0.05	0.09	375	
CV7204	CV7246	0.01	0.05	0.09	375	
CV7205	CV7247	0.015	0.055	0.095	375	
CV7206	CV7248	0.015	0.055	0.095	375	
CV7207	CV7249	0.02	0.06	0.10	375	
CV7208	CV7250	0.02	0.06	0.10	375	
CV7209	CV7251	0.02	0.06	0.10	375	
CV7210	CV7252	0.02	0.06	0.10	375	
CV7211	CV7253	0.02	0.06	0.10	375	
CV7212	CV7254	0.02	0.06	0.10	375	
CV7213	CV7255	0.02	0.06	0.10	375	
CV7214	CV7256	0.02	0.06	0.10	450	
CV7215	CV7257	0.02	0.06	0.10	450	
CV7216	CV7258	0.03	0.07	0.11	450	
CV7217	CV7259	0.03	0.07	0.11	450	
CV7218	CV7260	0.03	0.07	0.11	600	
CV7219	CV7261	0.03	0.07	0.11	600	
CV7220	CV7262	0.04	0.08	0.12	750	
CV7221	CV7263	0.04	0.08	0.12	750	
CV7222	CV7264	0.04	0.08	0.12	900	
CV7223	CV7265	0.04	0.08	0.12	900	
CV7224	CV7266	0.05	0.09	0.13	900	
CV7225	CV7267	0.05	0.09	0.13	1050	
CV7226	CV7268	0.06	0.10	0.14	1200	
CV7227	CV7269	0.06	0.10	0.14	1350	
CV7228	CV7270	0.06	0.10	0.14	1650	
CV7229	CV7271	0.06	0.10	0.14	1800	
CV7230	CV7272	0.06	0.10	0.14	1950	
CV7231	CV7273	0.06	0.10	0.14	2250	
CV7232	CV7274	0.06	0.10	0.14	2400	
CV7233	CV7275	0.06	0.10	0.14	2775	
CV7234	CV7276	0.06	0.10	0.14	3000	
Conditions	IR	mA	See Cal. 6, page 2.			1.0
	T <sub>stud</sub>	°C	25 - 100			25

T.V.C. Information Sheets Nos. 9 and 10.

Requirements:-

Marking. K1007, Section B, 1.3.4. Minimum requirements 1.3.4.1 (a) and (b).

Quality Assurance Provisions:-

Destructive Tests. The tests listed on Table II Group B Inspection, Subgroups 2, and 3, and in Table III Group C Inspection, Subgroup 2 are considered destructive.

Group C Inspection. Inspection shall be conducted on the initial lot and thereafter every 90 days or every fifth lot whichever occurs first.

Preparation for Delivery:-

Packaging. The devices shall be packed according to K1007, Section A, 1.2 (c). Items 1 to 6 inclusive shown in Fig. 2 page 12 shall be packed with each device.

Joint Service Catalogue Numbers:-

CV7193	5960-99-037-2600	CV7208	5960-99-037-2615
CV7194	5960-99-037-2601	CV7209	5960-99-037-2616
CV7195	5960-99-037-2602	CV7210	5960-99-037-2617
CV7196	5960-99-037-2603	CV7211	5960-99-037-2618
CV7197	5960-99-037-2604	CV7212	5960-99-037-2619
CV7198	5960-99-037-2605	CV7213	5960-99-037-2620
CV7199	5960-99-037-2606	CV7214	5960-99-037-2621
CV7200	5960-99-037-2607	CV7215	5960-99-037-2622
CV7201	5960-99-037-2608	CV7216	5960-99-037-2623
CV7202	5960-99-037-2609	CV7217	5960-99-037-2624
CV7203	5960-99-037-2610	CV7218	5960-99-037-2625
CV7204	5960-99-037-2611	CV7219	5960-99-037-2626
CV7205	5960-99-037-2612	CV7220	5960-99-037-2627
CV7206	5960-99-037-2613	CV7221	5960-99-037-2628
CV7207	5960-99-037-2614	CV7222	5960-99-037-2629

CV7223 5960-99-037-2630  
 CV7224 5960-99-037-2631  
 CV7225 5960-99-037-2632  
 CV7226 5960-99-037-2633  
 CV7227 5960-99-037-2634

CV7228 5960-99-037-2635  
 CV7229 5960-99-037-2636  
 CV7230 5960-99-037-2637  
 CV7231 5960-99-037-2638  
 CV7232 5960-99-037-2639

CV7233 5960-99-037-2640  
 CV7234 5960-99-037-2641  
 CV7235 5960-99-037-2642  
 CV7236 5960-99-037-2643  
 CV7237 5960-99-037-2644

CV7238 5960-99-037-2645  
 CV7239 5960-99-037-2646  
 CV7240 5960-99-037-2647  
 CV7241 5960-99-037-2648  
 CV7242 5960-99-037-2649

CV7243 5960-99-037-2650  
 CV7244 5960-99-037-2651  
 CV7245 5960-99-037-2652  
 CV7246 5960-99-037-2653  
 CV7247 5960-99-037-2654

CV7248 5960-99-037-2655  
 CV7249 5960-99-037-2656  
 CV7250 5960-99-037-2657  
 CV7251 5960-99-037-2658  
 CV7252 5960-99-037-2659

CV7253 5960-99-037-2660  
 CV7254 5960-99-037-2661  
 CV7255 5960-99-037-2662  
 CV7256 5960-99-037-2663  
 CV7257 5960-99-037-2664

CV7258 5960-99-037-2665  
 CV7259 5960-99-037-2666  
 CV7260 5960-99-037-2667  
 CV7261 5960-99-037-2668  
 CV7262 5960-99-037-2669

CV7263 5960-99-037-2670  
 CV7264 5960-99-037-2671  
 CV7265 5960-99-037-2672  
 CV7266 5960-99-037-2673  
 CV7267 5960-99-037-2674

CV7268 5960-99-037-2675  
 CV7269 5960-99-037-2676  
 CV7270 5960-99-037-2677  
 CV7271 5960-99-037-2678  
 CV7272 5960-99-037-2679

CV7273 5960-99-037-2680  
 CV7274 5960-99-037-2681  
 CV7275 5960-99-037-2682  
 CV7276 5960-99-037-2683

This specification has been prepared by and the Qualification  
 Approval Authority is:-

Admiralty Surface Weapons Establishment,  
 Portsdown, Cosham, Portsmouth, Hants., England.

## GROUP A INSPECTION

Table I

Examination or Test	Test Conditions		Insp. Level	Sym- bol	Limits		Units
	K1007/ NATO Ref.	Specific Conditions			Min.	Max.	
<u>SUBGROUP 1</u> Visual and Mechanical Inspection	5.1	Excluding Physical Dimensions	II				
<u>SUBGROUP 2</u> Breakdown Voltage	8A.2.4	T <sub>stud</sub> = 100°C + 2°C. IR = Col. 6 page 2. Single shot pulse, 0.1 sec duration, max. t <sub>r</sub> and t <sub>f</sub> = 10 nS.	II	V(BR)	Col. 4 page 2	Col. 5 page 2	V
Forward Volt Drop	8A.3.2	T <sub>stud</sub> = 25°C. I <sub>F</sub> = 2A.		V <sub>F</sub>		1.5	V
Small Signal Breakdown Impedance (1)	8A.4.1	T <sub>stud</sub> = 25°C. IR = Col. 6 page 2. Measurement to be made between 5 and 10 secs after the application of reverse current.		Z(BR)		Col. 7 page 2	Ω
<u>SUBGROUP 3</u> Small Signal Breakdown Impedance (2)	8A.4.1	T <sub>stud</sub> = 25°C IR = 1 mA. CV7199-CV7234 and CV7241-CV7276 only.	I	Z(BR)		Col. 8 page 2	Ω

Table I  
GROUP A INSPECTION (Cont'd.)

Examination or Test	K1007/ NATO Ref.	Test Conditions Specific Conditions	AQL %	Insp. Level	Sym- bol	Limits		Units
						Min.	Max.	
<u>SUBGROUP 4</u> Temperature Coefficient of Operating Voltage	8A.7.3	<p>IR = Col. 6 page 2.            T<sub>1</sub> = 25°C + 5°C.            T<sub>2</sub> = 100°C + 5°C.            Single shot pulse, 0.1 sec            duration, max. tr and tf            = 10 mS.</p> <p>Note:- Measured values of            T<sub>1</sub> and T<sub>2</sub> to be used            in calculating Sz.</p>	4.0	IA	Sz	Col. 3 page 3	Col. 5 page 3	%/°C

See Page 4 Quality Assurance Provisions

Examination or Test	Test Conditions		AQL %	Insp. Level	Sym- bol	Limits		Units
	K1007/ NATO Ref.	Specific Conditions				Min.	Max.	
<u>SUBGROUP 1</u> Physical Dimensions	5.1	According to drawing 10.3.3.2 and Fig. 2, page 12.	6.5	IC				
<u>SUBGROUP 2</u> Solderability	5.13		6.5	IC				
Temperature Cycling	5.5	-55°C to +150°C						
Moisture Resistance	5.3							
<u>SUBGROUP 3</u> Vibration Fatigue	5.15	Non-operating						
<u>SUBGROUP 4</u> Omitted.								
<u>SUBGROUP 5</u> Omitted.								
<u>SUBGROUP 6</u> Omitted.								
<u>SUBGROUP 7</u> High Temperature Life (Non-operating)	6.2.1 6.6.1.2.2	Tamb = 150°C. t = 1000 hrs.	6.5	IC				



Table II  
GROUP B INSPECTION (Cont'd.)

Examination or Test	Test Conditions		AQL %	Insp. Level	Symbol	Limits		Units
	K1007/ NATO Ref.	Specific Conditions				Min.	Max.	
<u>SUBGROUP 8</u> Operating Life  Post Test End Points for Subgroups 2, 3, 7 and 8 Breakdown Voltage  Small Signal Breakdown Impedance (2)	6.3 6.5 6.6.1.1 6.6.1.2.2	T stud not greater than 140°C. IR to give dissipation not less than the value corresponding to the chosen T stud, according to the derating curve Fig. 1, page 11.	4.0	IA				
	8A.2.4	As in Group A Inspection, Subgroup 2.			V(BR)	Col. 4 page 2	Col. 5 page 2	V
	8A.4.1	As in Group A Inspection, Subgroup 3.			Z(BR)		Col. 6 page 3	Ω

Table III

GROUP C INSPECTION

See Page 4 Quality Assurance Provisions

Examination or Test	Test Conditions		AQL %	Insp. Level	Sym- bol	Limits		Units
	K1007/ NATO Ref.	Specific Conditions				Min.	Max.	
<u>SUBGROUP 1</u> Omitted.								
<u>SUBGROUP 2</u> Shock	5.17	Non-operating Five blows each orientation : Y1, Y2, X and Z	6.5	IA				
<u>Post Test End Points</u> <u>for Subgroup 2</u> Breakdown Voltage	8A.2.4	As in Group A Inspection, Subgroup 2.			V(BR)	Col.4 page 2	Col.5 page 2	V
Small Signal Breakdown Impedance (2)	8A.4.1	As in Group A Inspection, Subgroup 3.			Z(BR)		Col.6 page 3	Ω

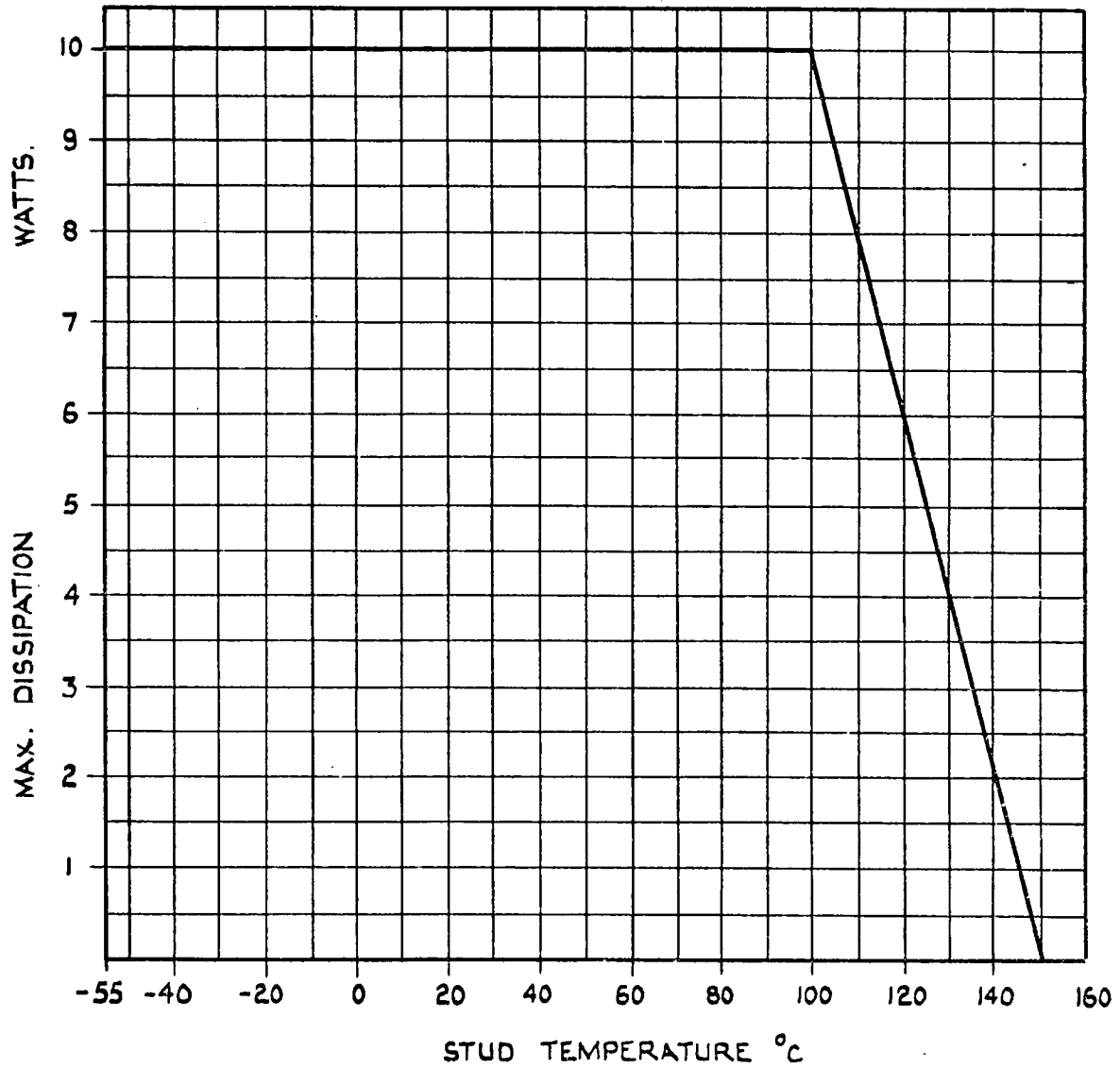
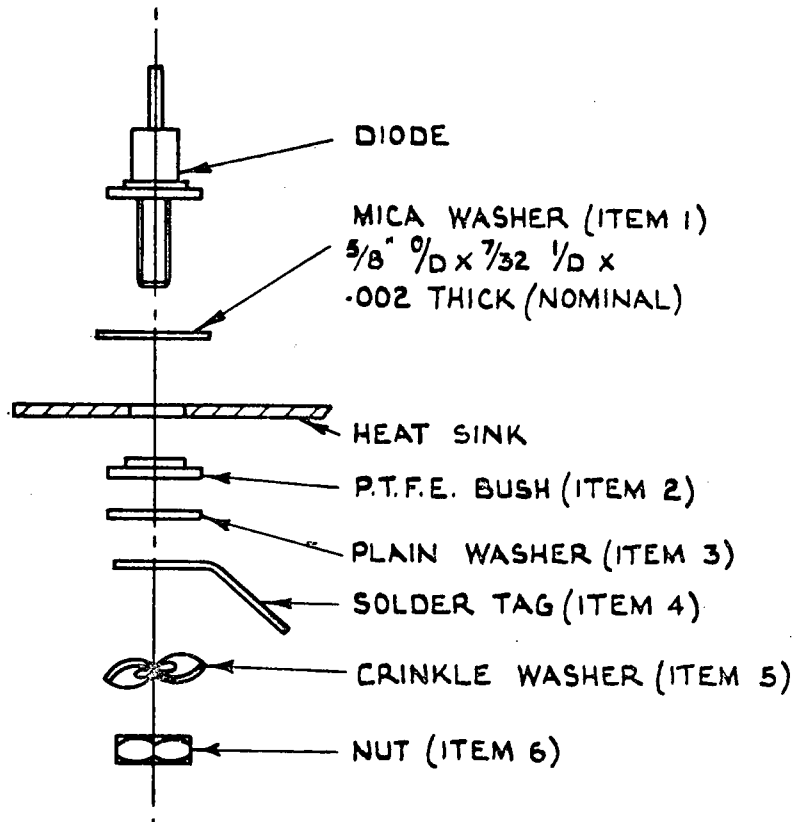
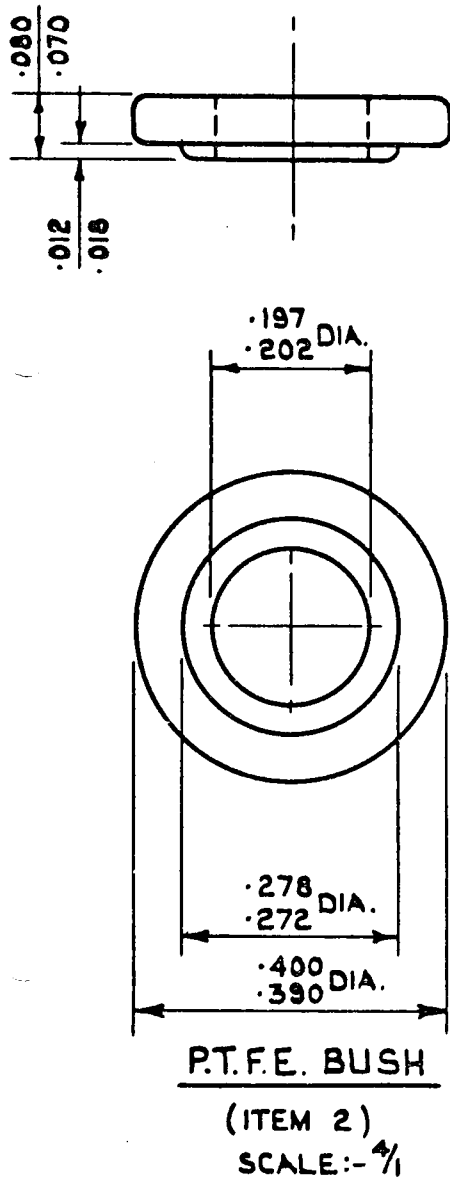

FIG. 1  
POWER DERATING



TYPICAL ASSEMBLY

SCALE  $\frac{1}{1}$

ALL METAL PARTS TO  
BE TINNED

MOUNTING TORQUE, WITH DRY  
THREAD = 12 IN. LBS. MIN.,  
15 IN. LBS. MAX.

FIG. 2